



CEILING MOUNTED PULL UP BAR ASSEMBLY INSTRUCTIONS

FOR YOUR SAFETY:

This pull up bar is designed to be mounted to wood frame ceiling with solid wood beams measuring 16 or 24 inches apart on center. This pull up bar should not be mounted to drywall alone. It is the users responsibility to choose a secure location and properly install the pullup bar using the instructions provide. Tighten all bolts and carefully examine your installation to ensure that the pull up bar is securely fastened in place before attempting to use the pull up bar.

Consult your physician before beginning this or any exercise program. If you experience any discomfort while using this machine, discontinue use and consult your physician immediately.

CMP - Ceiling Mounted Pull Up Bar with Dual Position Risers

PARTS LIST

1. Support Brackets x 2
2. Pull Up Bar
3. Curved Washers x 2
4. 40mm Allen Bolts x 2
5. Flat Washers x 4
6. Lag Bolts x 4
7. Allen Wrench
8. Mounting Template

TOOLS REQUIRED

- Power Drill
- Tape
- Pencil
- 5/16 in. Drill Bit
- Socket Drive Adapter for Power Drill (Recommended)
- 17mm Socket Wrench
- 17mm Open Socket

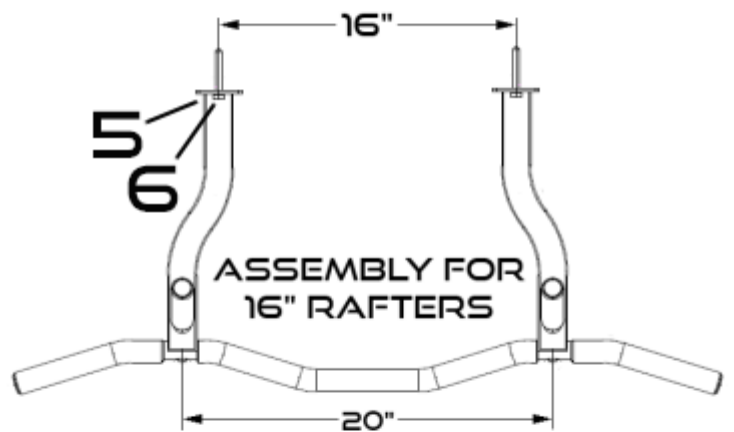
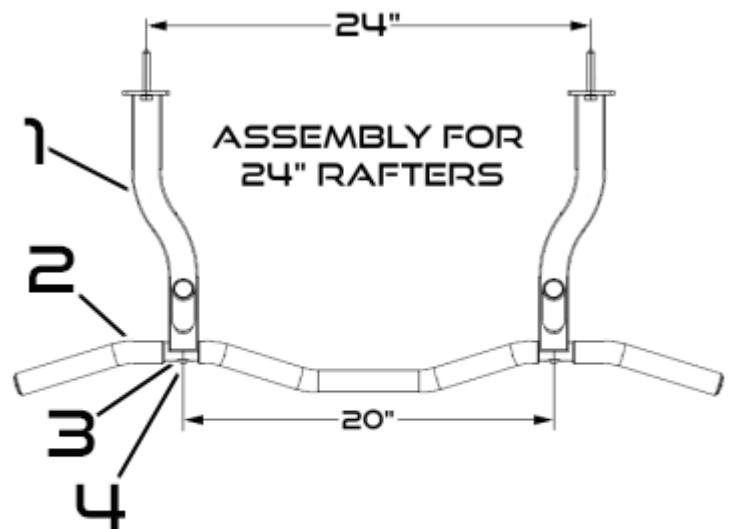

FRONT VIEW VARIATIONS



CEILING MOUNTED PULL UP BAR ASSEMBLY INSTRUCTIONS

INSTALLATION

1. This pull up bar is designed to be mounted directly to solid wood rafters measuring 16 or 24 inches apart on centers.
2. Find two rafters measuring 16 or 24 inches apart on centers.
3. Mark the location of the center of each rafter.
4. **Pull Up Bar Assembly:** Attach the Pull Up Bar to the Support Brackets using the two allen bolts and curved washers. Do not fully tighten bolts until final installation is complete.
 - a. For 16" rafter spacing attach support brackets so they curve inward towards each other.
 - b. For 24" rafter spacing attach support brackets so they curve outward away from each other.
5. Using tape attach the mounting template to the ceiling with the desired hole spacing located over the center of each rafter.
6. Pre-drill four pilot holes to a depth of 3 inches using a 5/16 inch bit. **For an easier, more secure installation and to avoid damage to rafters and hardware make sure your 5/16 inch drill bit length, when installed on the power drill, is at least 3 inches.**
7. Attach pull up bar assembly to the ceiling using four lag bolts and flat washers. For a quicker installation use a power drill, Socket Drive Adapter and 17mm socket to drive bolts.
8. Tighten all bolts and carefully examine your installation to ensure that the pull up bar is securely fastened in place before attempting to use the pull up bar.

